

ARTEMIS™

A

GEORGE
KOVACS®

DESIGN

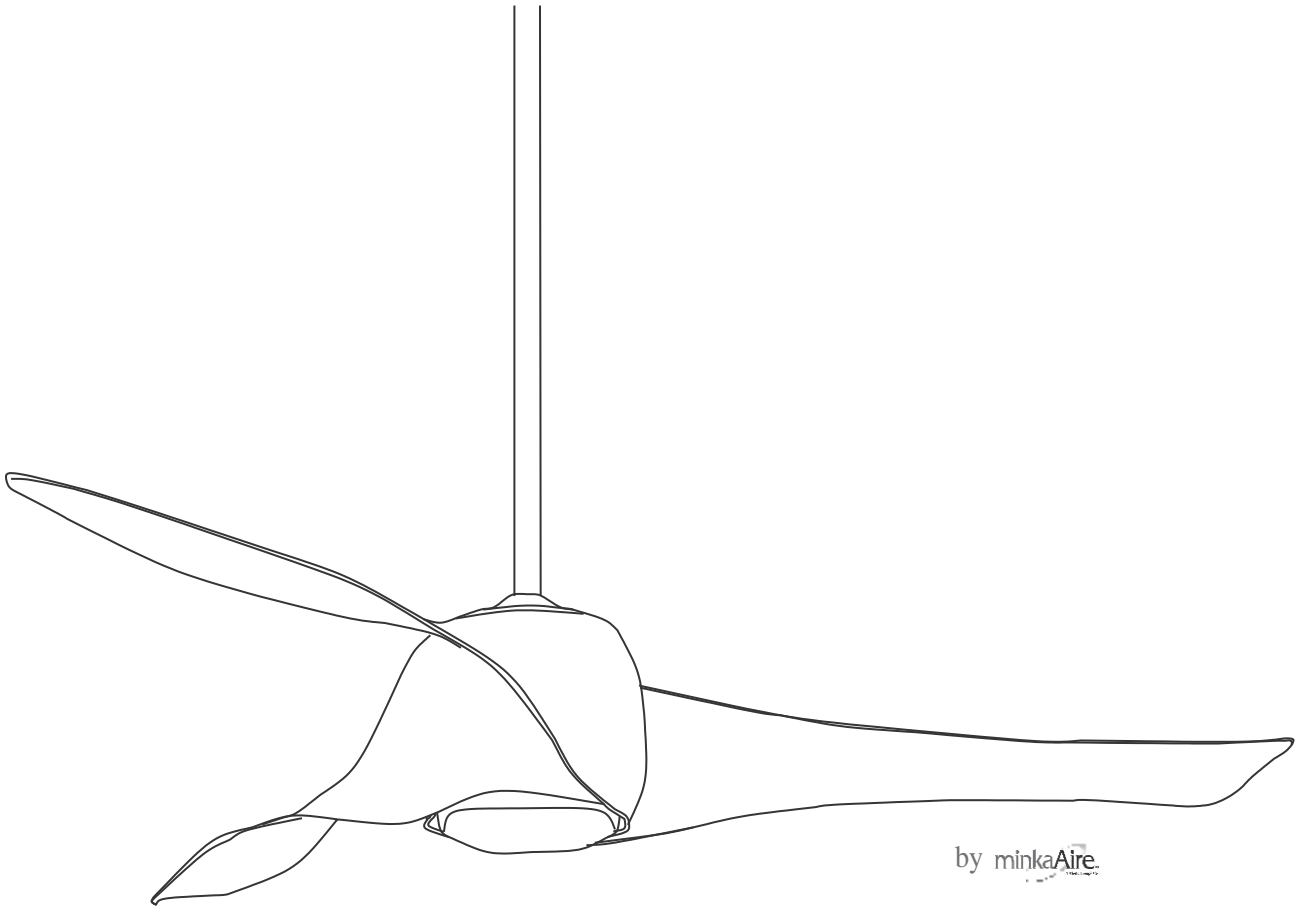

by minkaAire.

U.S. Patents: D535,011; D535,015; D535,387; D535,388; D536,083; 7,481,626

INSTRUCTION MANUAL WARRANTY CERTIFICATE

CONTENTS

SAFETY PRECAUTIONS.....	1
IMPORTANT NOTES.....	2
PACKAGE CONTENTS.....	3
TOOLS REQUIRED.....	4
INSTALLING THE MOUNTING BRACKET.....	4
HANGING THE FAN.....	5
ELECTRICAL WIRING DIAGRAM.....	7
ELECTRICAL CONNECTIONS.....	8
FINISHING THE INSTALLATION.....	10
BLADE INSTALLATION.....	10
INSTALLING THE LIGHT KIT MOUNTING PLATE.....	11
INSTALLING THE LIGHT PLATE.....	11
INSTALLING THE LIGHT BULB & GLASS SHADE.....	12
USING YOUR CEILING FAN.....	12
BALANCING / WOBBLING TROUBLE SHOOTING.....	14
FAN CARE AND WARRANTY INFORMATION.....	14
WARRANTY SERVICE.....	15
RIPPLE CONTROL.....	16
TROUBLE-SHOOTING CHECKLIST.....	17
SPECIFICATION.....	17
WARRANTY CONDITIONS.....	18
CEILING FAN WARRANTY DETAIL.....	20



For Customer Assistance Call: 1800 602 243

Congratulations on purchasing your new Artemis ceiling fan by Minka Aire. This is an extremely high quality product and we are sure that you will be very happy with your purchase. Despite thorough quality control and testing sometimes issues can arise. We want you to be thoroughly happy with your product and ownership experience. Please read this manual for installation and refer to it if problems arise.

SAFETY PRECAUTIONS

The information contained in the following pages has been prepared to ensure you of trouble-free operation of your Ceiling Fan .

1. To ensure the success of the installation be sure to read the instructions and study the diagrams thoroughly.
2. For your safety, all electrical connection and disconnection must be performed by a Licensed Electrician.
3. The fixing point for the fan must be able to support a weight of at least 40kg. If you are mounting the fan to a ceiling junction box, the box and it's fixing must be able to support the moving weight of the fan and must not twist or work loose.
4. The fan must be earthed.
5. Do not connect the fan motor to a dimmer switch. This may give an unsatisfactory performance (motor hum) and cause damage to the motor. Only use the wall controller supplied.
6. It is not recommended that ceiling fans and gas appliances be operated in the same room at the same time.
7. To prevent damage the fan must be turned off and stopped completely before reversing the fan direction.
8. Do not insert anything into the fan blades while the fan is operating, as this may cause injury, damage the blades and upset the balance of the unit causing it to wobble.
9. Once the fan is completely installed make sure that all connections are secured and tightened to prevent any problems.
10. Due to the fan's natural movement, some connections may loosen. Check the support connections, brackets and blade attachments twice a year to make sure they are all secured. If they are loose, tighten with a suitable tool.

Note: The important safeguards and instructions given in this manual are not meant to cover all possible conditions and situations that may occur. It must be understood that common sense, caution and care are factors which cannot be built into any product.

For installation advice, or in the unlikely event of damaged or missing parts please consult a licensed electricians

IMPORTANT NOTES

FAN CONTROL

Your warranty will be void if a solid-state dimmer type fan controller or other brand wall controller is used. ONLY use the wall controller supplied.

With these controllers there is a strong possibility that the ceiling fan motor will produce an unpleasant loud humming noise.

FAN INSTALLATION

Under our warranty terms this ceiling fan must be installed by a licensed electrician. Ceiling fans installed incorrectly can be dangerous and expensive to repair. This voids the warranty too. This fan is designed for indoor use only, mounting where the fan is subject to water or moisture can be dangerous and also void the warranty.

FAULT FINDER

Always check the “Trouble Shooting Checklist” included in this booklet before calling for service. Unnecessary calls are inconvenient for all and can attract a service charge.

MECHANICAL NOISE MAY BE NOTICED ON INSTALLATION, PLEASE ALLOW AT LEAST 8 HOURS SETTling-IN PERIOD. SOME FANS WOBBLE MORE THAN OTHERS—EVEN IN THE SAME MODEL; IT DOES NOT MEAN THE FAN IS FAULTY.

WARNING

This appliance is not intended for use by persons (including children) with reduced physical, sensory or mental capabilities, or lack of experience and knowledge, unless they have been given supervision or instruction concerning use of the appliance by a person responsible for their safety.

Children should be supervised to ensure that they do not play with the appliance.

PACKAGE CONTENTS

Unpack your fan and check the contents. You should have the following items:

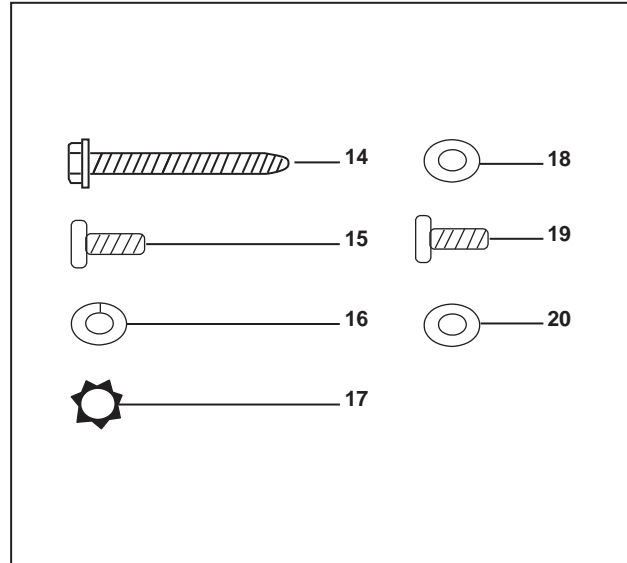
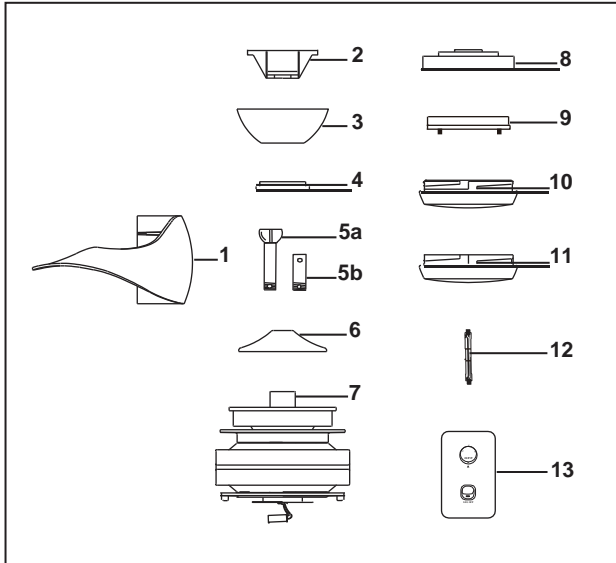

1. Fan blades x 3
2. Hanger bracket x 1
3. Canopy x 1
4. Canopy cover x 1
- 5a. Standard downrod assembly x 1
- 5b. Minimum-length downrod (for close to ceiling mounting only) x 1
6. Coupling cover x 1
7. Fan motor/housing assembly x 1
8. Light kit mounting plate x 1
9. Light plate x 1
10. Glass shade x 1
11. Optional metal switch cup cover x 1
12. 80W R7S halogen bulb x 1
13. Wall control Incl. 2 mounting screws

14. #10 x 38 mm Wood screws x 2
15. #8 x 19 mm Machine screws x 2
16. Lock washers x 2
17. 4mm Star washers x 2
18. Washers x 2
19. 4.8 mm x 17mm Screws x10
20. Flat washers x 10

TOOLS REQUIRED

Tools Required:

- Phillips / Flat head screw driver
- Pair of pliers
- Adjustable Spanner
- Step ladder
- Wire cutter
- Wiring, supply cable as required by AS/NZS 3000 wiring code.

INSTALLING THE MOUNTING BRACKET

The ceiling fan must be installed in a location so that the blades are at least 2.1 meters above the floor, and 30cm spacing from the tip of the blade to the nearest objects or walls.

Secure the hanging bracket to the ceiling joist or structure that is capable of carrying a load of at least 40KG, with two long screws provided. Ensure at least 30mm of the screw is threaded into the support.

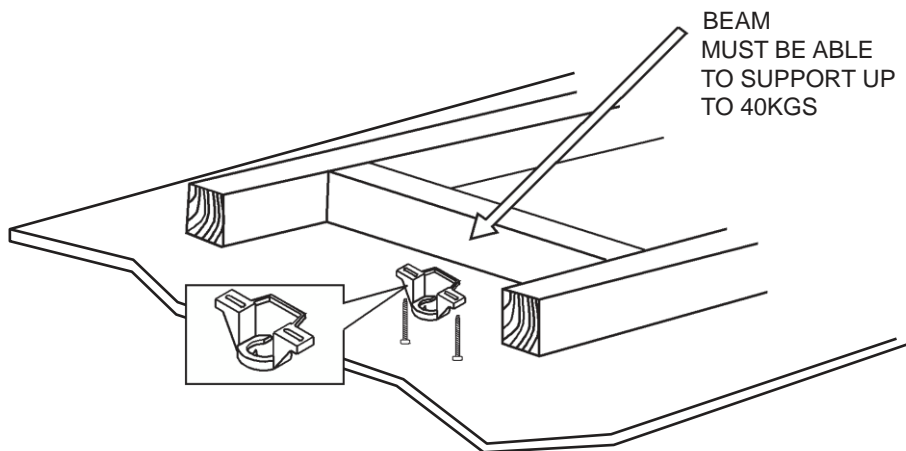

Fig. 1

NOTE: PICTURE IS FOR REPRESENTATION ONLY AND DO NOT REPRESENT THE ACTUAL BRACKET.

NOTE: The bracket screw provided is for use with wooden structure only. For structures other than wood, the appropriate screw type **MUST** be used.

HANGING THE FAN

WARNING: All of the parts, hardware and components such as the hanger bracket and hanger ball have been provided for your safety and the proper installation of your new ceiling fan. The use of other parts, hardware or components not supplied by Minka Aire® with the fan will void the Minka Aire® Warranty.

Loosen the screw in the terminal block and remove the terminal block for later use. Secure the hanger bracket to the ceiling joist or structure using the screws included. Re-install the terminal block back to hanger bracket.

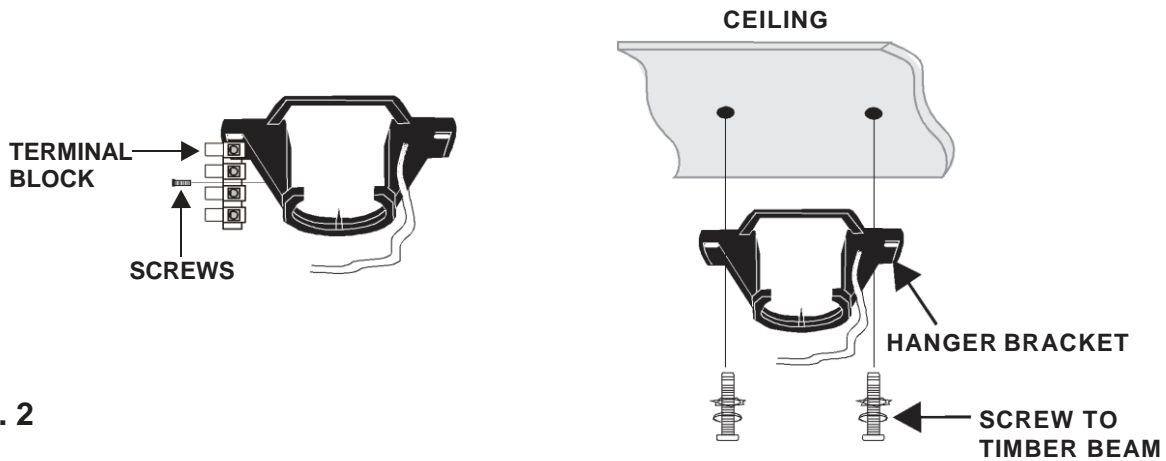

Fig. 2

Loosen the two set screws and remove the hitch pin and lock pin from the top coupling of the motor assembly.

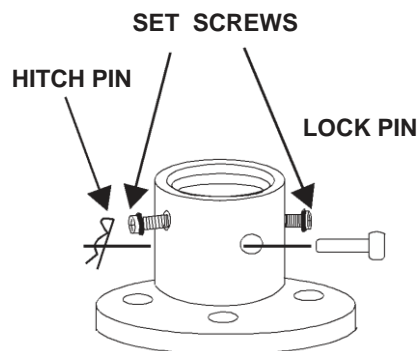

Fig. 3

Remove hanger ball from downrod assembly by loosening set screw, removing the cross pin, and sliding ball off rod.

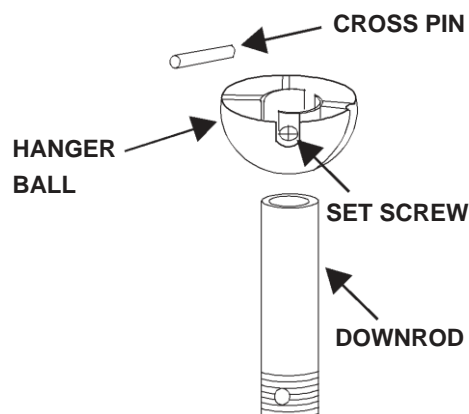

Fig. 4

Carefully feed fan wires up through the downrod, then thread the rod into the coupling. Line up the holes and replace lock pin and hitch pin. Tighten set screws.

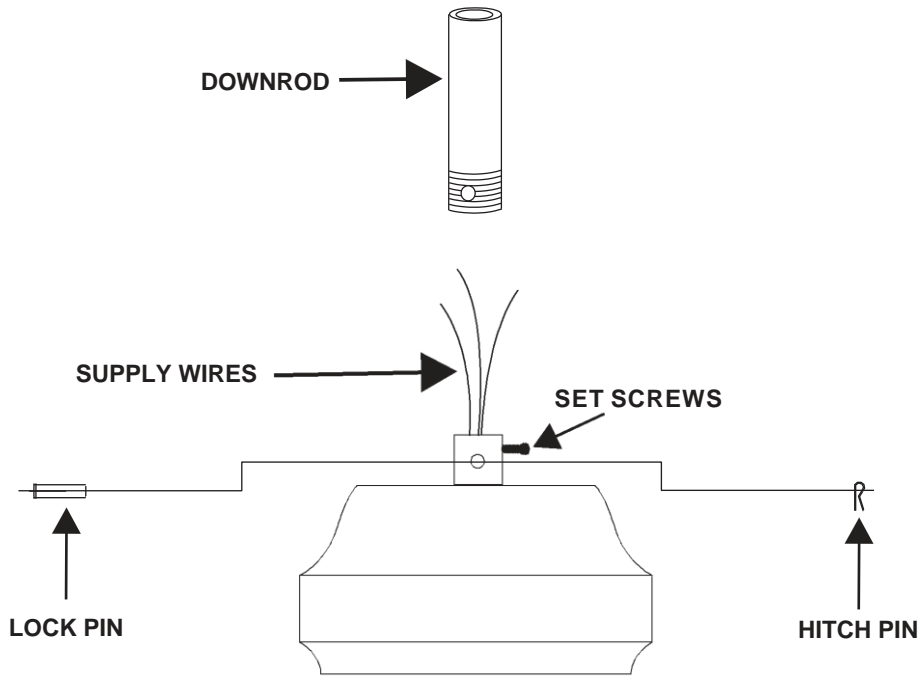

Fig. 5

Slip coupling cover, canopy cover and canopy onto downrod. Install two screws into coupling cover and tighten screws to fix it. Carefully reinstall hanger ball onto rod being sure that cross pin is in the correct position, check screws are tight and wires are not twisted.

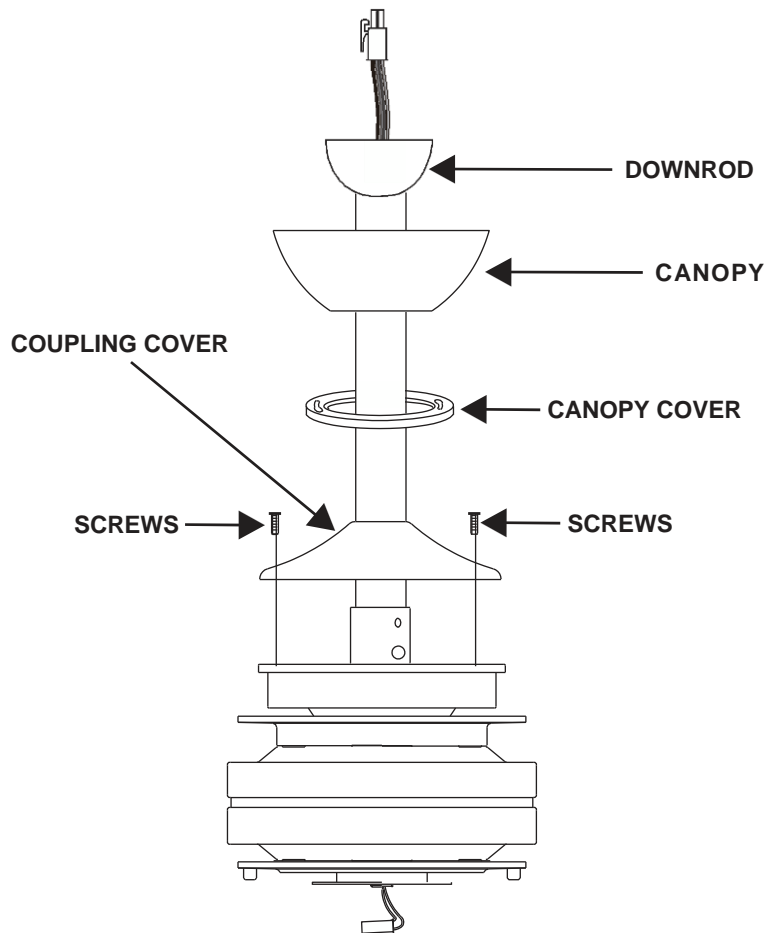

Fig. 6

Now lift motor assembly into position and place hanger ball into hanger bracket. Rotate until the check groove has dropped into the registration slot and seats firmly. Rod should not rotate if this is done correctly.

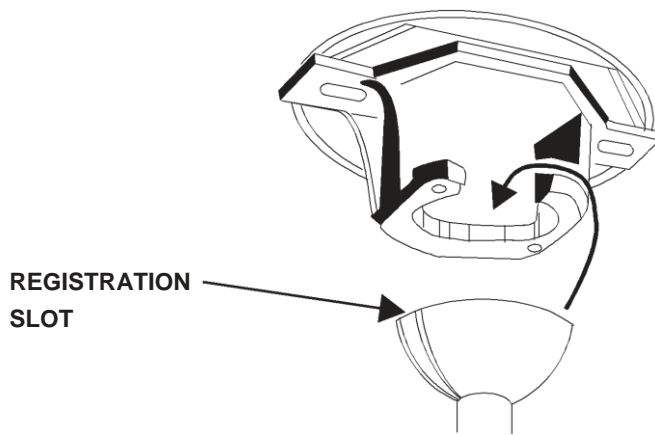

Fig. 7

ELECTRICAL WIRING DIAGRAM

WARNING: FOR YOUR SAFETY , ALL ELECTRICAL CONNECTIONS MUST BE UNDERTAKEN BY A LICENCED ELECTRICIAN

NOTE: AN ADDITIONAL ALL POLE DISCONNECTION SWITCH MUST BE INCLUDED IN THE FIXED WIRING.

Install the wall switch:

1. Remove the wall plate and switch from the wall junction box.
2. Remove the knob and switch cover by using the flat screwdriver.
3. Set all knobs on the wall control in the off position.

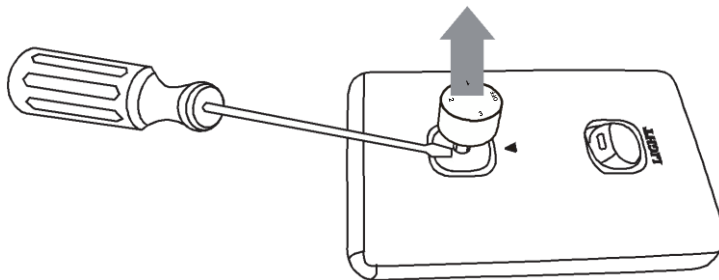

Fig. 8

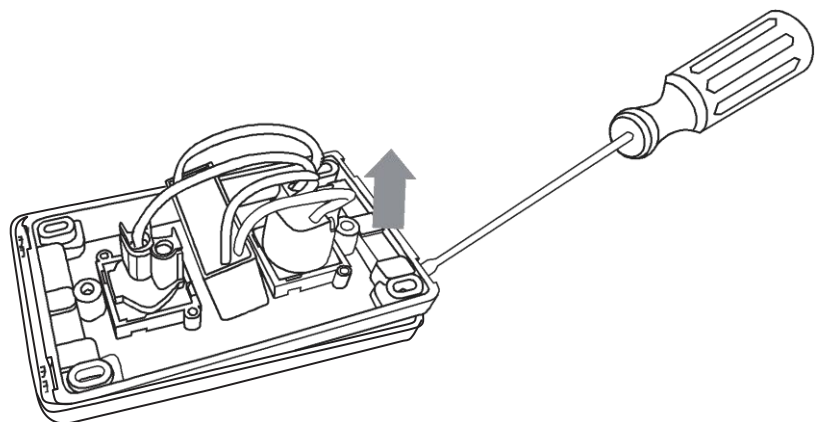

Fig. 9

ELECTRICAL CONNECTIONS

Make wiring connection as following:

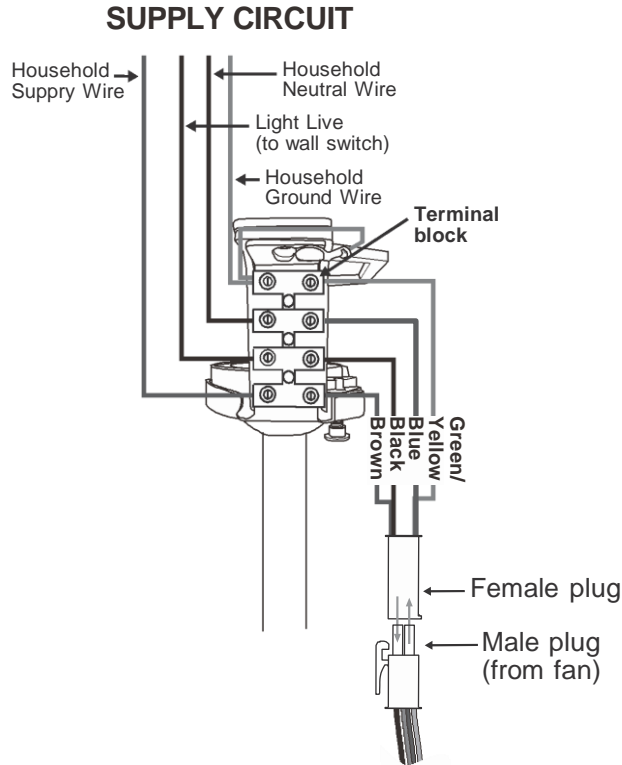

Fig. 10

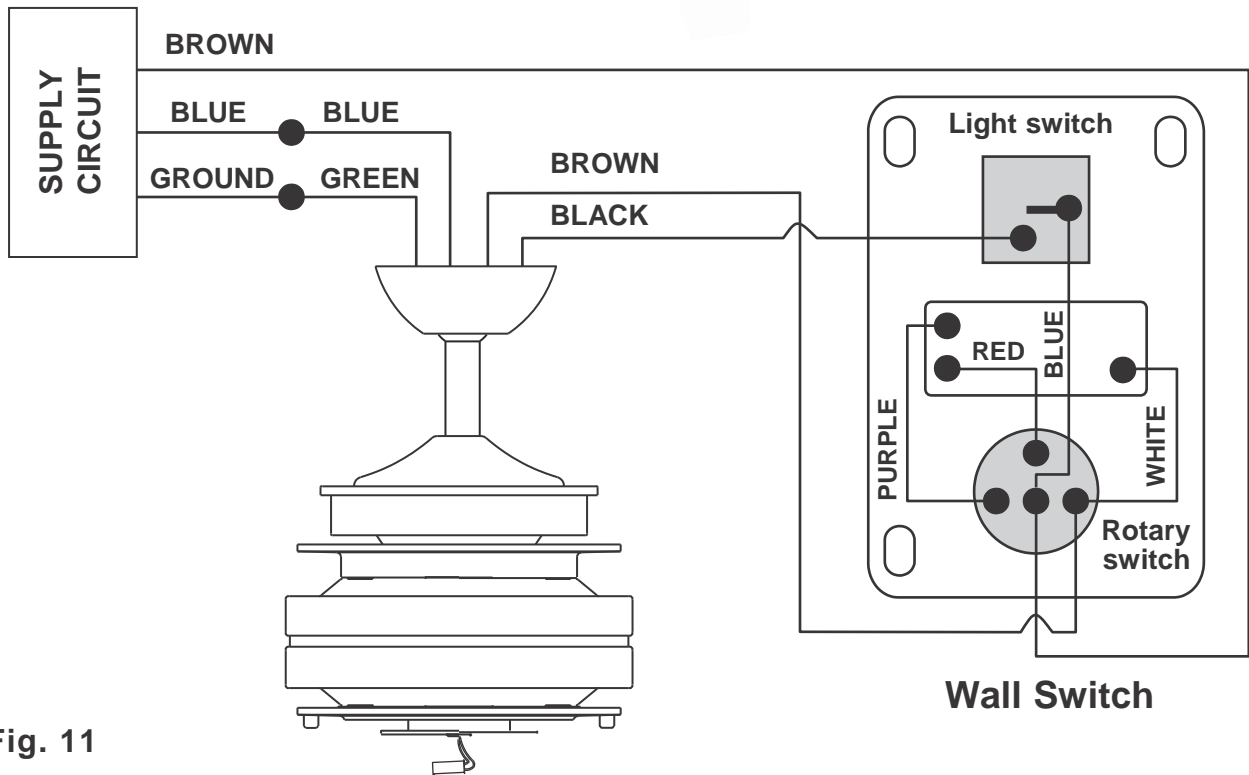

Fig. 11

NOTE: The light switch wiring diagram is omitted for models that do not have the light feature

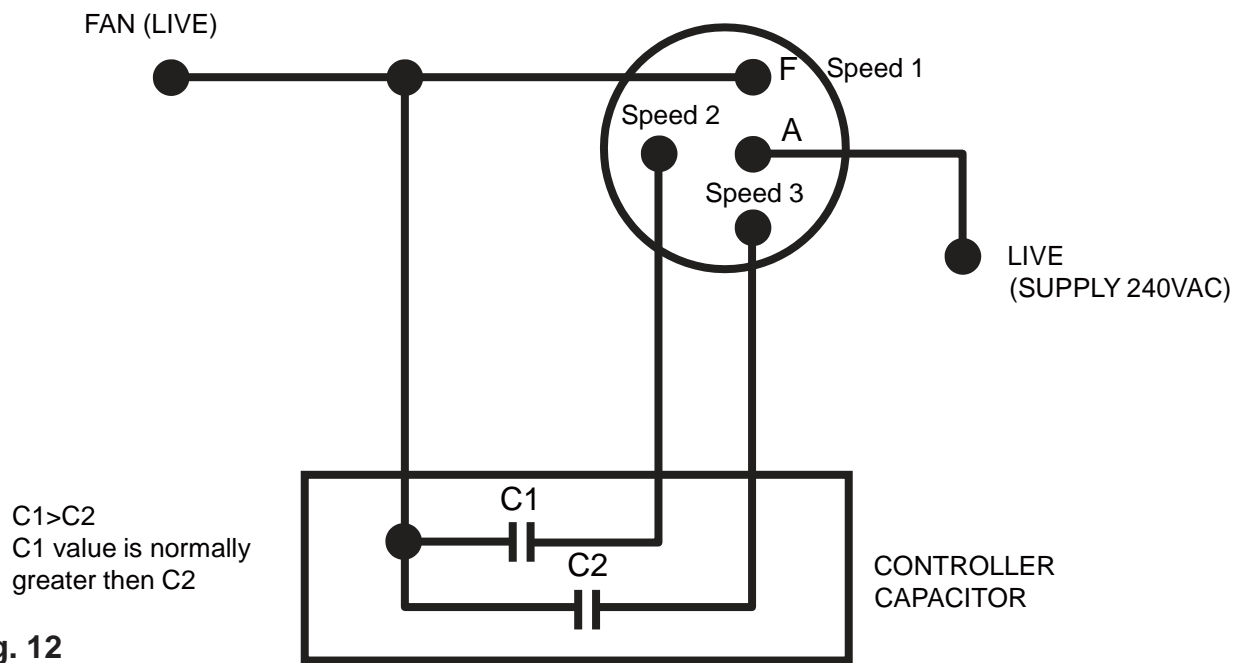

Fig. 12

Carefully tuck the wire connections inside the outlet box or wall cavity if not using an outlet box. Use the screws provided to secure the wall switch and wall plate to the outlet box or wall switch frame.

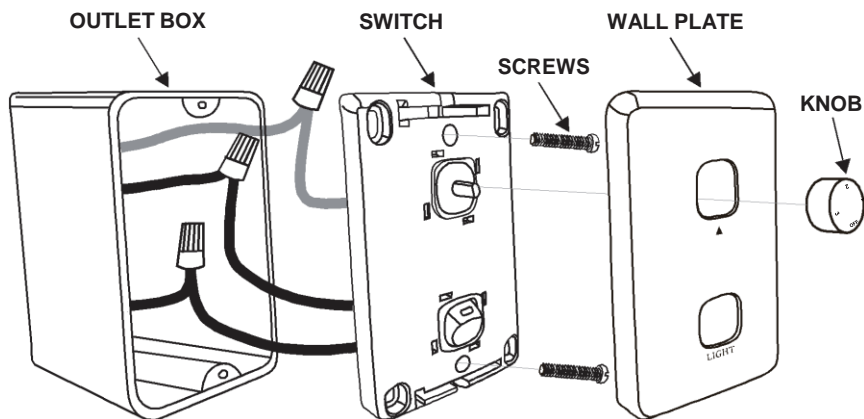

Fig. 13

Note: Outlet box is not included, and can be supplied separately by the Electrician.

FINISHING THE INSTALLATION

1. Remove 1 of 2 screws from the bottom of the hanger bracket and loosen the other one a half turn from the screw head.
2. Slide the canopy up to the hanger bracket and place the key hole on the canopy over the screw on the hanger bracket, turn canopy until it locks in place at the narrow section of the key holes.
3. Align the circular hole on the canopy with the remaining hole on the hanger bracket, secure by tightening the two screws.

NOTE: Adjust the canopy screws as necessary until the canopy and canopy cover are snug.

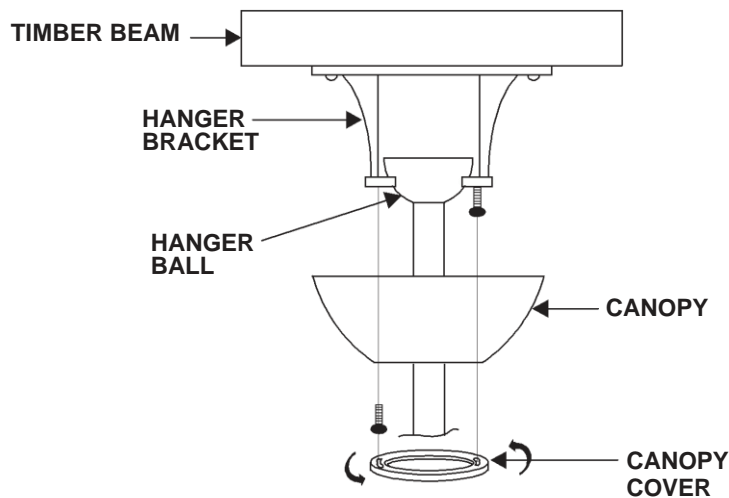

Fig. 14

BLADE INSTALLATION

1. Align and engage the top holes from one of the blades to the upper blade holder tabs. Carefully align the bottom holes from the blade to the holes from the lower blade holder. Secure blade with the 3 screws, lock washers and flat lock washers provided. Follow the same process for the remaining two blades.
2. All blade sets are grouped together by weight. Plastic materials vary in density, therefore the fan may wobble even though the blades are weight matched.

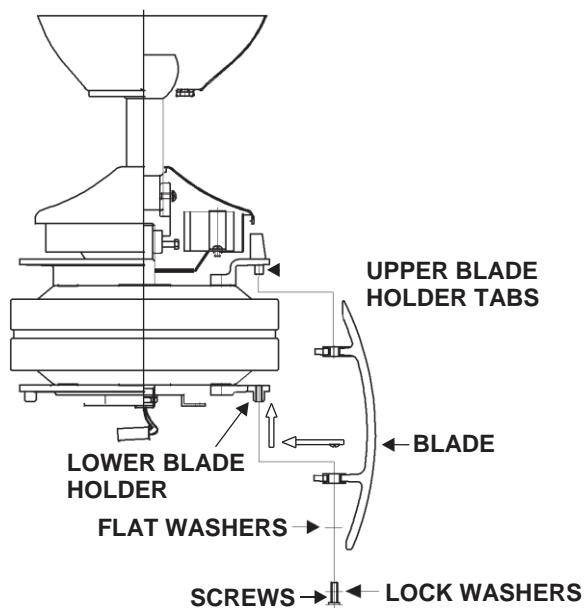

Fig. 15

NOTE: You must attach the blades to the motor housing after mounting the motor to the ceiling. When installing more than one fan, ensure that the blades sets are not mixed up as each set is dynamically balanced.

INSTALLING THE LIGHT KIT MOUNTING PLATE

1. Remove 3 screws from the mounting ring.
2. Place the light kit mounting plate to the mounting ring, secure by tightening the 3 screws previously removed.

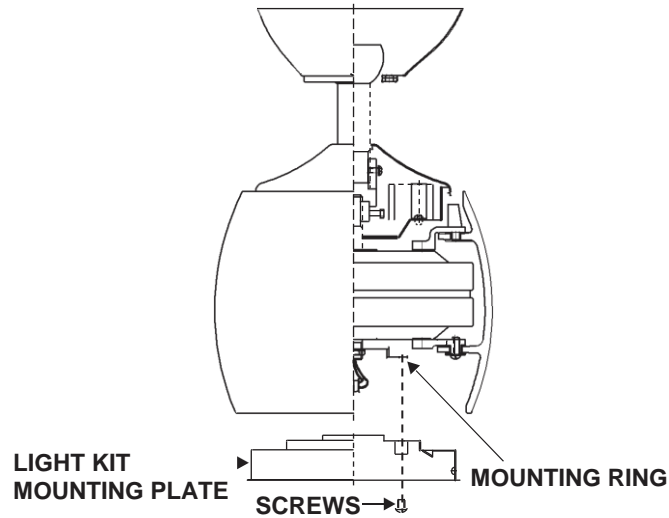

Fig. 16

INSTALLING THE LIGHT PLATE

NOTE: Before starting installation, disconnect the power by turning off the circuit breaker or removing the fuse at fuse box.

1. Remove the 3 screws from the mounting plate.
2. Raise and hold the light plate close to the mounting plate and proceed to do the wire connections. Connect the white wire connectors from the light plate and fan, follow the same procedure with the black wire connectors.
3. Install and Secure the light plate by tightening the 3 screws previously removed.

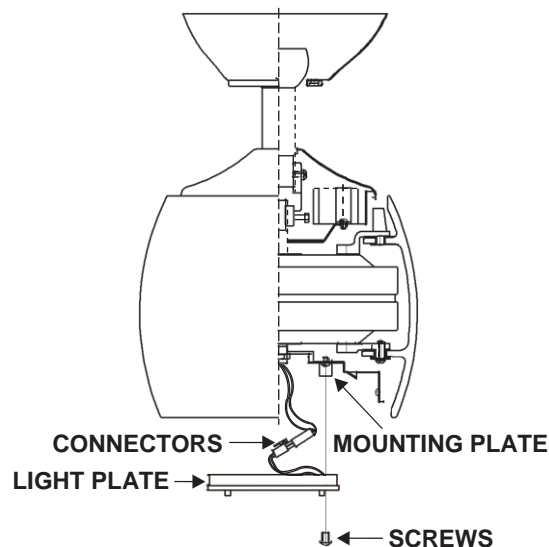

Fig. 17

INSTALLING THE LIGHT GLOBE & GLASS SHADE

WARNING: Shut off the power supply before removing or replacing the globe. Care should be taken when handling the halogen globe and it should not be touched with bare hands. Oil residue will shorten the life of the halogen globe. If you accidentally come into contact, wipe thoroughly with a clean, lint-free, cotton cloth. Allow the globe to cool off for 10 minutes before changing it. Use light globe in accordance with the fan's specification. **TO REDUCE THE RISK OF FIRE DO NOT EXCEED MAXIMUM WATTAGE RATING.**

Install 80W R7S halogen globe (included). (Disregard this step if using the optional switch cup cover) Raise glass shade or optional switch cup cover up against bottom of fan housing and secure it to fan by turning it clockwise until snug. **DO NOT OVERTIGHTEN.**

Note: If installing the optional metal switch cup cover, make sure it is securely tightened.

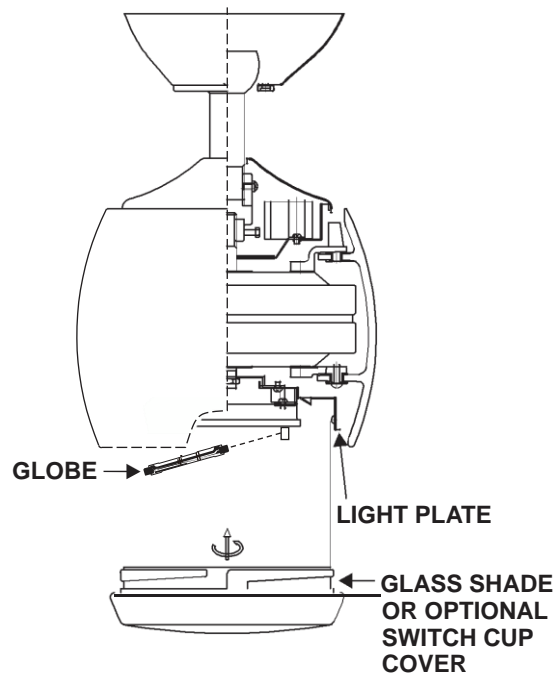

Fig. 21

USING YOUR CEILING FAN

FAN WALL CONTROL

Turn on the power and check the operation of the fan.

- OFF Position – fan off
- 3rd Position – low medium fan speed
- 2nd Position – medium fan speed
- 1st Position – high fan speed

Light Control

- Toggle Switch – on/off

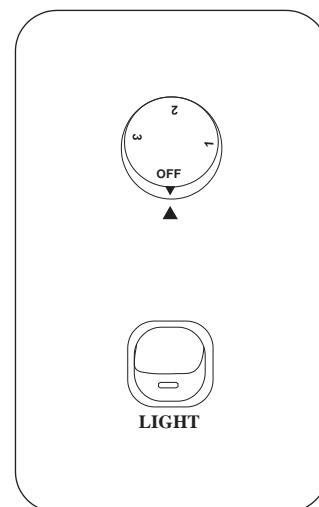

Fig. 22

REVERSING SWITCH

Your ceiling can operate either in fan mode or reverse fan mode.

NOTE: to change the direction of the rotation of the blades the fan must not be operating.

The Reverse switch is located on the top of the motor housing. Slide the switch to the left for warm weather operation. Slide the switch to the right for cool weather operation.

Warm Weather (forward)

A DOWNWARD airflow creates a cooling effect as shown in Figure 23. This allows you to set your air conditioner on a warmer setting without affecting your comfort.

Cool Weather (Reverse)

An UPWARD airflow moves warmer air off the ceiling area as shown in Figure 24. This allows you to set your heating unit on a cooler setting without affecting your comfort.

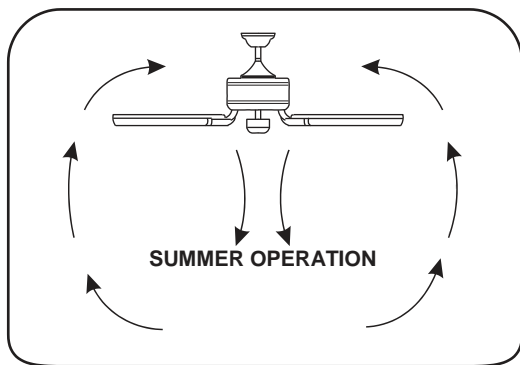

Fig. 23

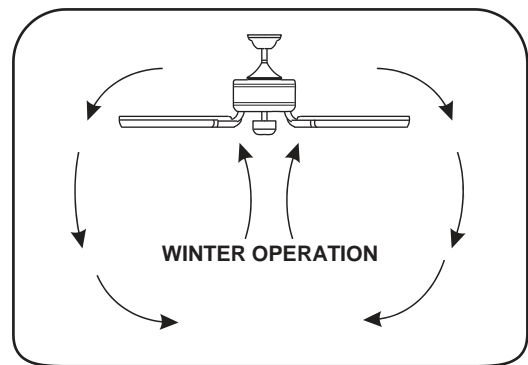

Fig. 24

BALANCING / WOBBLING TROUBLE SHOOTING

Please note that all ceiling fans are not the same, even in the same model—some may move more or less than others. Movement of a couple of centimetres is quite acceptable and does not suggest the fan will fall down.

Even though all blades are weighted and grouped by weight, it is impossible to eliminate wobble altogether and should not be considered a problem. Ceiling fan tend to move during operation because they are not generally rigidly mounted

You may do the following to reduce wobbling:

- 1) Check all the blade mounting screws are tight and secure.
- 2) Wobbling problems may result from inconsistent blade level. To check blade level, measure the distance from each blade tip to the ceiling.
Note: If measurements are inconsistent:
 - check blade mount screws are not over tightened or loose which can cause the blade tips not to be level.
- 3) Blade tracking may be checked simply by use of a household ruler as shown in the below Figure. 25. Place the ruler vertically against the ceiling. Line up the outside edge of one of the blades of the ceiling fan and note the measurement on the ruler. Turn the blade slowly by hand to check that the other remaining blades match up to the same point on the ruler. If the blades are not aligned it may mean that a blade may be out of shape or warped or the screws securing the blades to the motor are not evenly tightened or are too loose.

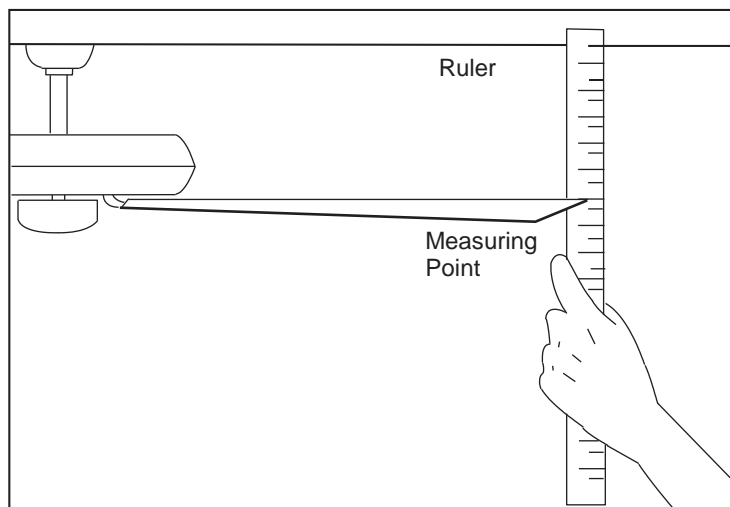

Fig. 25

FAN CARE AND WARRANTY INFORMATION

CARE & CLEANING

- Periodic cleaning of your ceiling fan is the only maintenance required. Use a soft brush or lint free cloth to avoid scratching the paint/plated finish. Please make sure the fan is not operating when cleaning.
- Do not use water when cleaning your ceiling fan. It could damage the motor or the blades and create the possibility of an electrical shock.
- Motor has permanently lubricated ball bearing.

WARRANTY SERVICE

The manufacturer warranty covers actual faults that may develop, but NOT minor complaints, e.g. noise from motor run—ALL ELECTRIC MOTORS ARE AUDIBLE TO SOME EXTENT.

WOBBLE

- Ceiling fans tend to move during operation due to the fact that they are not generally rigidly mounted—if they were, they could generate excessive ceiling vibration and stress on their mountings.
- Movement of a couple of centimetres is quite acceptable and does not suggest the fan will fall down.
- Ceiling fans are mounted very securely on steel brackets with rubber cushioning or with ball-joints to allow free movement.
- Please note that all ceiling fans are not the same, even in the same model—some may move more or less

NORMAL WEAR AND TEAR

Threaded components that are slightly loose or blade carriers that are slightly bent due to vigorous cleaning or bumping can cause extra wobble and noise. THIS IS NOT COVERED UNDER WARRANTY- a little care and maintenance can reduce or prevent this problem.

BUMP-IN-THE NIGHT

This is the biggest cause for service calls, which are outside the manufacturer's warranty. If a fan has a fault, it will be noticeable at all times. Naturally, when everything is quiet at night, you will be more inclined to hear small noises, which may not be noticeable at other times. Even slight power fluctuations and mains frequency signals superimposed in your electricity supply for off-peak hot water control may cause a change in fan motor noise, this is normal.

FAN LIGHT

Except for actual faults in manufacturing which are extremely rare, FAN LIGHTS AND GLOBES ARE NOT COVERED UNDER YOUR FAN WARRANTY. Noises and vibration etc. are often more accentuated when a fan light is fitted.

For instance a fan light glass that has not been tightened or has worked loose can cause a rattle. Again, care and maintenance will reduce this.

If glass is broken replacements can be purchased from the retailer.

WARNING

- The fan must be installed so that the blades are more than 2.1 meters above the floor. According
- to law in Australia, all electrical connections must be made by a licensed electrician. According to
- our warranty terms, only the fans installed by a licensed electrician will be warranted.

NOTES TO INSTALLERS

- All electric motors, including fans make some noise and may feel hot if touched—this is not a fault.
- Some fans wobble more than other—even in the same model.
- Fan lights can rattle, but are not covered under warranty
- Fan wall controller make slight buzz and get warm especially on lower setting.
- All these occurrences are not covered by the manufacturer's warranty.

RIPPLE CONTROL **(abstract from Hunter Pacific International)**

Throughout Australia, but in particular Sydney and other parts of NSW and Queensland, electricity distributors use a remote control and switching system that is commonly called ripple control. Ripple control has existed for many years and is used for controlling demand and implementing different customer tariffs.

Our electricity supply is 240 Volts AC 50 Hertz. AC means alternating current, a type of electrical energy that flows in one direction for half a cycle, and then the opposite direction for the other half cycle. 50 Hertz means there are fifty cycles per second. For electrical and electronic products a cycle rate of 50 Hertz is very slow and therefore the wires carrying the power can also carry other signals. Ripple control systems superimpose signals on the 50 Hertz mains supply so they can be distributed throughout a local power grid. Ripple control signals are used to switch on and off high power consumption equipment such as water heaters and water supply pumps. Electrical equipment such as televisions, toasters, fans, fluorescent and halogen lighting and some appliances may be sensitive to ripple control signals. This results in an audible buzz being generated whenever the signals are present. As different frequencies for these signals are used in different areas, products may respond in some areas and not others. Some areas have more than one ripple control system in operation and different signals may be present at different times and affect different products.

WILL I BE AFFECTED?

In areas that have ripple control installed for off-peak tariff switching (such as off-peak hot water systems) there is usually a dual tariff meter installed, or dual meters. A smaller control box marked "Zellweger" may also be present. The meter or Zellweger box will usually have the ripple control signal frequency marked on it (for example 1050 Hz). Even if you do not have off-peak equipment installed your power supply may still be affected by ripple control signals. Apart from looking for the control signal marking in your meter box there is no way of knowing in advance if you will be affected by ripple control signal noise.

WHAT CAN I DO IF I AM AFFECTED?

There are ripple control signal filters available for sale from experienced lighting and fan dealers. These filters have to be installed by a licensed electrician and each filter has to be matched to the particular signals in your area. Your dealer usually knows the signals used in their local area and can recommend the correct filter.

It is not possible to build an electric motor based product that rejects all the ripple control signals and the signals differ from location to location. If you are affected by ripple control noise in your fan or lighting product please contact your local dealer to purchase the appropriate filter. The cost of the filter and the cost of installation are not covered by the purchase price of the fan or light. Occasionally the ripple control signals are so strong they cannot be sufficiently filtered.

WARRANTY CLAIMS:

Ripple control signal noise is not covered by warranty. If you make a warranty based service call for ripple control noise, you will be charged for the call-out by the electrician if he/she does not find a genuine fault with the product.

TROUBLE-SHOOTING CHECKLIST

TROUBLE	PROBABLE CAUSES	SUGGESTED REMEDY
1. Fan will not start (Warning: The ceiling fan must be switched OFF and the assistance of a licensed electrician maybe required.)	A. Fuse or circuit breaker blown.	Check main and branch circuit fuses or circuit breakers.
	B. Loose power line connections to the fan.	Check line wire connections to fan
	C. Speed controller not in correct position.	Check speed controller's position.
2. Fan Wobbles (Refer to Wobble section of the manual for further information.)	A. Fan blades are not horizontal to ceiling.	Refer to "wobbling fixing" section of manual. - The blade may require adjustment at the blade mounting screws; - The blade is out of shape, thus causing wobbling. New blades set will require to be replaced. Contact your local Beacon Lighting store.
	B. Blade screws are loose.	Make sure all screws are securely fastened.
4. Mechanical Noise	A. Top canopy touching ceiling.	Lower Canopy from ceiling to ensure minimum 3 mm clearance.
	B. Loose fan blade screws.	Re-tighten all screws on fan blades but never over-tighten.
	C. Ceiling fan not secured against ceiling.	Re-tighten all screws in the hanging bracket or plate.
	D. Incorrect speed controller.	Change the controller to the one supplied.
	E. Audible buzzing noise. Caused by Ripple Control signals. Please refer to the Ripple Control section of this manual.	Install a Ripple Control filter. (Refer to the Ripple control information in this manual.)
3. Fan sound noisy	A. Allow at least 8 hours settling-in period.	
5. Light will not turn ON (Optional light kit ONLY)	The globe/lamp has failed.	Replace globe/lamp.

WARNING: THE CEILING FAN MUST BE SWITCHED OFF, BEFORE ANY TROUBLESHOOTING IS PERFORMED.

SPECIFICATION

FAN Models	Rated Voltage	Rated power (motor)	Rated power lamp (for models with light only)	Lamp type
Artemis F803	220 - 240 VAC	70W	MAX. 80W	R7S

WARRANTY CONDITIONS

This product is guaranteed against electrical defects in material or manufacturing workmanship for faults when under normal domestic/residential conditions for 24 months from the date of purchase. This warranty covers parts and labour costs for the motor subject to the following conditions:

1. Installation being performed by a qualified licensed Electrician.

This warranty will not apply if the ceiling fan is installed by anyone other than a licensed electrician. Problems arising from incorrect installation are not covered by warranty. The cost of repairs and/or service call where the defect is due to the installation and not due to faulty material or workmanship, in accordance with the wholesaler and their authorized agent, will be payable at time of repair

2. Repair work being carried out by a licensed electrician only after authorisation by the wholesaler or their authorized agent to complete the repair and is subject to the supply of dated proof of purchase and installing electricians details.

3. Painted and/or plated finishes of the ceiling fan are only covered under warranty for 6 months.

4. The warranty service does not cover:

- a. Repair of defects caused by accident, fire, misuse, alterations modification, negligence, incorrect or incomplete installation/operation, any unauthorized person attempting to repair the ceiling fan, or acts of God.
- b. Claims or damage to furniture, carpet, wall, ceiling foundations or any other consequential loss either direct or indirectly resulting from a faulty ceiling fan.

5. Except in the case of pre-packed integrated light models, light fittings attached to the fan are not covered by this warranty. Where the fan is pre-packed complete with a light, the light fitting will be covered by warranty for electrical defect. Tarnishing caused by climatic conditions and breakage of glasses is not covered by warranty. Globes are also not covered by warranty. All light fittings attached to the fan must be installed by a qualified licensed Electrician, ensuring such attachments are complete and do not affect the fan's performance. Light fittings can accentuate noises and vibrations, which can be traced to loose glass or fittings and are not covered by warranty. Broken glass as supplied in the pre-packed light complete models is not considered an item requiring a warranty service call. Notification within 48 hours of installation is required where glasses have found to be broken on unpacking.

6. The warranty applies to actual faults which may develop. Minor running noises are not covered. All electrical motors have some audible noise. Allow at least eight hours of operation to allow the bearings to properly seat. The fan, especially when set on low, may feel warm to touch – this is not a fault. If excessive heat is generated a service call may be required. Fan noises can vary due to slight power fluctuations and mains frequency signals for off – peak-controlled appliances. These changes are most noticeable in the quiet of night, mains frequency signals which come across as an intermittent hum (mostly at night) are out of control of the manufacturer in these cases your electricity provider should be contacted, or an electrician to fit a suitable noise filter. (See section relating to ripple control)

7. Threaded components such as blade nuts can work slightly loose during normal operation. These should be tightened regularly to ensure the fan doesn't develop operation noises. If noises do develop, check this aspect before requesting service. This is not covered by warranty.

8. Minor variation of speed may be evident between different fans, even in the same model and is not a product fault and not covered by warranty.

9. Blades are not covered by warranty against defect in material. The replacement of the blades is not covered by the in home warranty service call, Notification within 48 hours of installation is required where blades have found to be broken on unpacking, contact the wholesaler or their authorized agent who will send you a new set of blades. Each blade set is balanced so it is important to replace all blades. Blades affected by climatic conditions and by maintenance are not covered by this warranty.

This warranty applies only to Australian states; its mainland territories and New Zealand. The benefits of this warranty are in addition to any benefits offered under state or territory law.

For warranty service, contact the hotline number in this booklet and advise: the model number and style, the nature of the fault, date and place of purchase. Service cannot be arranged without this information.

Prior to requesting service, please consult the Trouble-shooting checklist that is printed in the manual.

CEILING FAN WARRANTY DETAIL
LUCCI WARRANTY HOTLINE- 1800 602 243

In the event of service being required, please call the Lucci Fan Warranty Hotline on 1800 602 243 between 9am & 5pm (EST) Monday to Friday. Please make sure you have all the ceiling fan details filled out at the end of the manual before making the call.

Every Lucci Design ceiling fan is thoroughly inspected and tested before being released for sale. In addition to any warranties or conditions implied by applicable Statute or Regulation, Lucci Design warrants all of its ceiling fans against defective workmanship and faulty materials for twenty four (24) months from the date of purchase. Lucci Design undertakes, at its option, to repair or replace, free of charge, each product or part thereof on condition that;

1. The fan or relevant part has not been subjected to misuse, neglect, or been involved in an accident.
2. The repairs are not required as a result of normal wear and tear.
3. The product was installed by a licensed electrical contractor.
4. A copy of the original receipt of purchase is presented.
5. 12 month warranty applies when used in any non domestic applications.
6. This warranty does not cover stains, scratch and scuff marks, or dents if the product is purchased through factory outlet or refurbish items.

Lucci Design cannot be held responsible for any repair other than those carried out by it or one of its Authorised Service Agents. Please keep this warranty information in a safe place. This information must be produced in the event of service being required.

CEILING FAN WARRANTY DETAIL
LUCCI WARRANTY HOTLINE- 1800 602 243

Retain AND Fill in this form and keep it for your personal records and warranty purposes

NAME _____

ADDRESS _____

POSTCODE _____

MODEL NUMBER _____

PO NUMBER or DATECODE _____

DATE OF PURCHASE _____

STORE PURCHASED FROM _____

INSTALLING LICENSED ELECTRICIAN _____

PHONE _____

INSTALL DATE _____

CERT. OF ELECTRICAL SAFETY # : _____

LICENCE No _____

ATTACH PROOF OF PURCHASE HERE

THIS COMPLETED DETAIL PAGE SHOULD BE PRODUCED AND FAXED TO THE WHOLESALE OR THEIR AUTHORISED AGENTS BEFORE OBTAINING WARRANTY SERVICE